

Tachometer in Volvo Amazon

WHEN THE TOP OF THE LINE MODEL 123GT was introduced in 1967 it came with a tachometer. This was assigned part number 281046 and was manufactured by Smiths for Volvo. The tachometer is transistorized and features a warning field for excessive engine speeds. Its placement on the dash pad is best illustrated by a picture (see below). The same tachometer was later sold as an accessory to Volvo Amazon, and is included in the 1969 accessories catalogue.



Smiths revolution counter on foot has five cables: one black, two red and two white. Install the unit by connecting the black to ground. The one of the two red cables is connected to the instrument lighting by the lighting switch and the other red cable to the 25 A fuse (the upper, bolder fuse in the fuse box). The one white cable is connected on the coil instead of the black (which is removed) and the other white cable is connected to the distributor (where the just removed black cable was). If the tach doesn't work, switch the two white cables.

P 130

Reservdelskatalog
Parts catalogue



Sida Page	Grupp Group	INSTRUMENT MED MONTERINGSDETALJER		INSTRUMENT AND INSTALLATION COMPONENTS		Utgåva Issue		
44	3					3		
Pos. Fig.	Antal Qty			Detalj nr Part No	Benämning	Description	Sats/Kit	Anmärkning Notes
13	1	.	.	281046-3	VARVRÄKNARE	REVOLUTION.		SPEC UTF 5314
14				682963-4	.FRONTKÄPAFRONT HOUSING		
15					.GLAS.LENS		LAGERFÖRES EJ
16					.PACKNINGPACKING.		LAGERFÖRES EJ
17					.RINGRING		LAGERFÖRES EJ
18				672585-7	.BRICKAWASHER.		
19				672586-5	.VINGMUTTERBUTTERFLY NUT		
20				667512-8	GUMMIBUSSNING	RUBBER BUSHING		SPEC UTF 5576

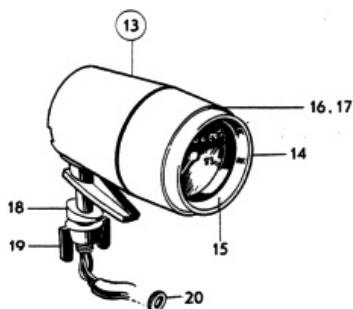



The Smiths tachometer that came factory installed on the 123GT differs somewhat from the Smiths tachometer that was later sold as accessory in that it has a chrome ring and a 10 X 100 RPM grading; the accessory tachometer has a matte ring and a 1 X 1000 RPM grading. Both have the same part number, 281046. The picture to the left is from the accessories catalogue and, mistakenly, shows the 123GT tachometer.

Waiver. The text in this summary has been prepared with uttermost care but is, despite of this, strictly a guide to be used in conjunction with normal and cautious vehicle shop practice, including the safe operation of electric equipment. I cannot accept liability for your actions. Work safely!